

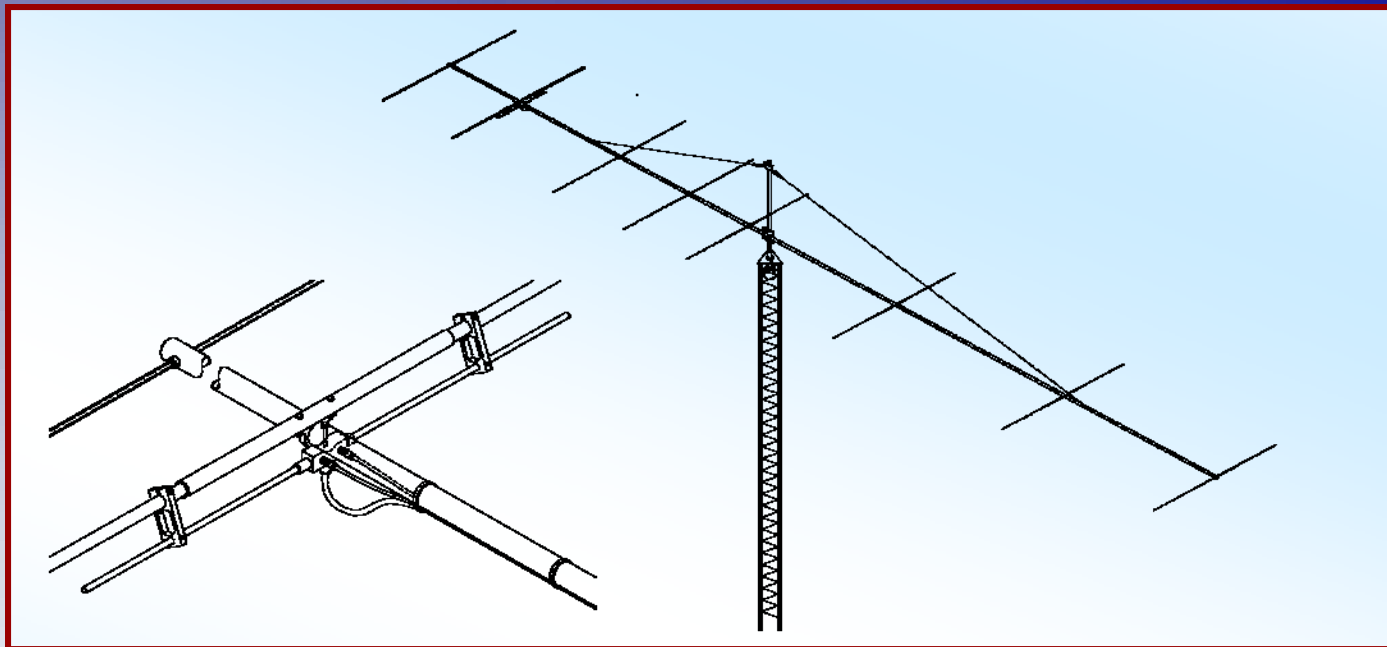

# M2 Antenna Systems, Inc. Model No: 6M2WLC



## SPECIFICATIONS:

Model .....	6M2WLC	Power Handling .....	3 kW
Frequency Range.....	50 To 50.7 MHz	Boom Length / Dia.....	39' 6" / 2-1/2" To 2"
*Gain .....	14.0 dBi	Maximum Element Length.....	9' 9"
Front to back .....	25 dB Typical	Turning Radius: .....	21' 8"
Beamwidth .....	E=36° H=39°	Stacking Distance.....	27" High & 29" Wide
Feed type .....	"T" Match	Mast Size.....	1-1/2" to 2" Nom.
Feed Impedance. ....	50 Ohms Unbalanced	Wind area / Survival .....	5 Sq. Ft. / 100 MPH
Maximum VSWR.....	1.2:1 @ 50.120 mHz	Weight / Ship Wt.....	48 Lbs. / 54 Lbs.
Input Connector.....	"N" Female		

**\*Subtract 2.14 from dBi for dBd**

## FEATURES:

The 6M2WL was conceived and designed to produce maximum gain and performance around 50.1 MHz. Countless hours of computer optimization and range confirmation resulted in an antenna which will set a new standard for long boom Yagis. It is an excellent stand alone antenna but for the adventurous, it is a perfect building block for spectacular 6 meter array gain.

The driven element is a 3/4" diameter tube for improved efficiency and bandwidth, fed by a 'T' match with adjustable shorting bars. Stainless screws lock the joints together. The "T" match block is CNC-machined and internal connections are sealed with a space-age silicone gel with dielectric strength nearly 4 times greater than air. All three connectors feature 'O' ring seals. The balun cable features double seals; one at the cable and one inside the connector where it mates with the female. This match block configuration was developed at M2 for shipboard ATS satellite use and is now used on all our amateur Yagis.

The parasitic element design meets the stringent requirement for extreme durability consistent with minimal windload and visibility. Elements are a solid rod of 1/4" 6061-T6 aluminum rod with a 3/8" x 36" center reinforcing sleeve, double crimp-locked to the rod. The elements pass through the rugged boom and are insulated with special UV stabilized button insulators designed to dampen vibrations and prolong element life. Elements are locked in place with stainless steel keepers. Thousands of these elements are currently in service in large commercial arrays with ZERO failures to date!

# 6M2WLC ASSEMBLY MANUAL

TOOLS REQUIRED: Screwdriver, 11/32 wrench, socket or spintite, a 7/16" and 1/2" wrench or socket, tape measure. For best results please review instructions before assembly.

1. Assemble the boom starting with the rear 2" x 95" straight section with the three 5/8" diameter element mounting holes. The end with a 5/8" hole located in 1" is the REAR of the boom. Mate the other end to the swaged end of the 2-1/2" x 95" section (with 5/8" dia. hole closer to its swaged end). Align the holes, insert the 1/4-20 x 2-3/4" bolts and locknuts and tighten. The next section in line is the 2-1/2 x 95" piece with both ends swaged. Orient this piece with the 5/8" hole diameter pointed toward the rear of the boom. Slide the swaged end into the previous boom section, and secure with 1/4-20 x 3" bolts and locknuts. Now add the other 2-1/2 x 95" section, sliding the unswaged end onto the other side of the both ends swaged section. Secure with 1/4-20 x 3" bolts and locknuts. Locate the other 2 x 95 straight section and insert into the swaged end of the last section. Secure with 1/4-20 x 2-3/4" bolts and locknuts.

2. Lastly, insert the swaged end of the 2 x 19.5" section into the free end of the previous boom section and secure with 1/4-20 x 2-1/2" bolts and locknuts.

3. It may be convenient to add the boom to mast plate at this time. The 6 x 8 x 1/4 plate mounts approximately 218" (18' 2") from the REAR of the boom. Use two 2-1/2 inch U-bolts and cradles and the 5/16" stainless steel lockwashers and nuts. TEMPORARILY position the plate under the boom and parallel with the element holes. This way the boom can be laid across a bench or bucks and the plate will keep the boom from rotating while installing the elements. Now is a good time to install the front and rear 5/16 x 4" eyebolts. See the DIMENSION SHEET for their location.

4. Locate the single machined 2 inch ring clamp and slide it about 36" from the REAR of the boom. Loosely install a 1/4-20 x 1" bolt and locknut in the clamp fingers. The driven element will mount on this ring clamp later in the assembly.

5. Lay out the elements in the order they install in the boom. The longest is the reflector (118-3/4") and it mounts at the rear end of the boom section in the 5/8" hole one inch from the end. First balance the element across your finger to find approximate center. Now slide on one black button insulator to about 1 inch off center using the 5/8 x 3" PVC PUSHER TUBE. ***The insulators can be a tight fit. Place them in hot water for a few moments to expand or run a 3/8" drill through the center hole to ease installation.*** Insert the element through the boom while sliding the second button insulator on as the element tip is passing through the boom. Fit the first insulator into the boom hole and push the second insulators up tight against the boom. Don't bother to center accurately at this point. It is quicker to do when all the elements are in place.

6. Continue installing the ROD elements in the following order:

LENGTH:		POSITION:
108"	(9')	D1 (just ahead of Driven element)
108"	(9')	D2
108-3/4"	(9' 3/4")	D3
107-3/8"	(8' 11-3/8")	D4
106"	(8' 10")	D5
105.5"	(8' 9-1/2")	D6
106"	(8'10")	D7 (Front director)

7. Now begin centering the elements using a tape measure. REFER to the ANTENNA DIMENSION SKETCH for one side **EXPOSED HALF LENGTH** dimensions. Accuracy of +/- 1/16" is fine. Double check your centering by looking for identical half length dimensions on either side of the boom.

# 6M2WLC DIMENSION SHEET

(VIEW FROM BOTTOM)

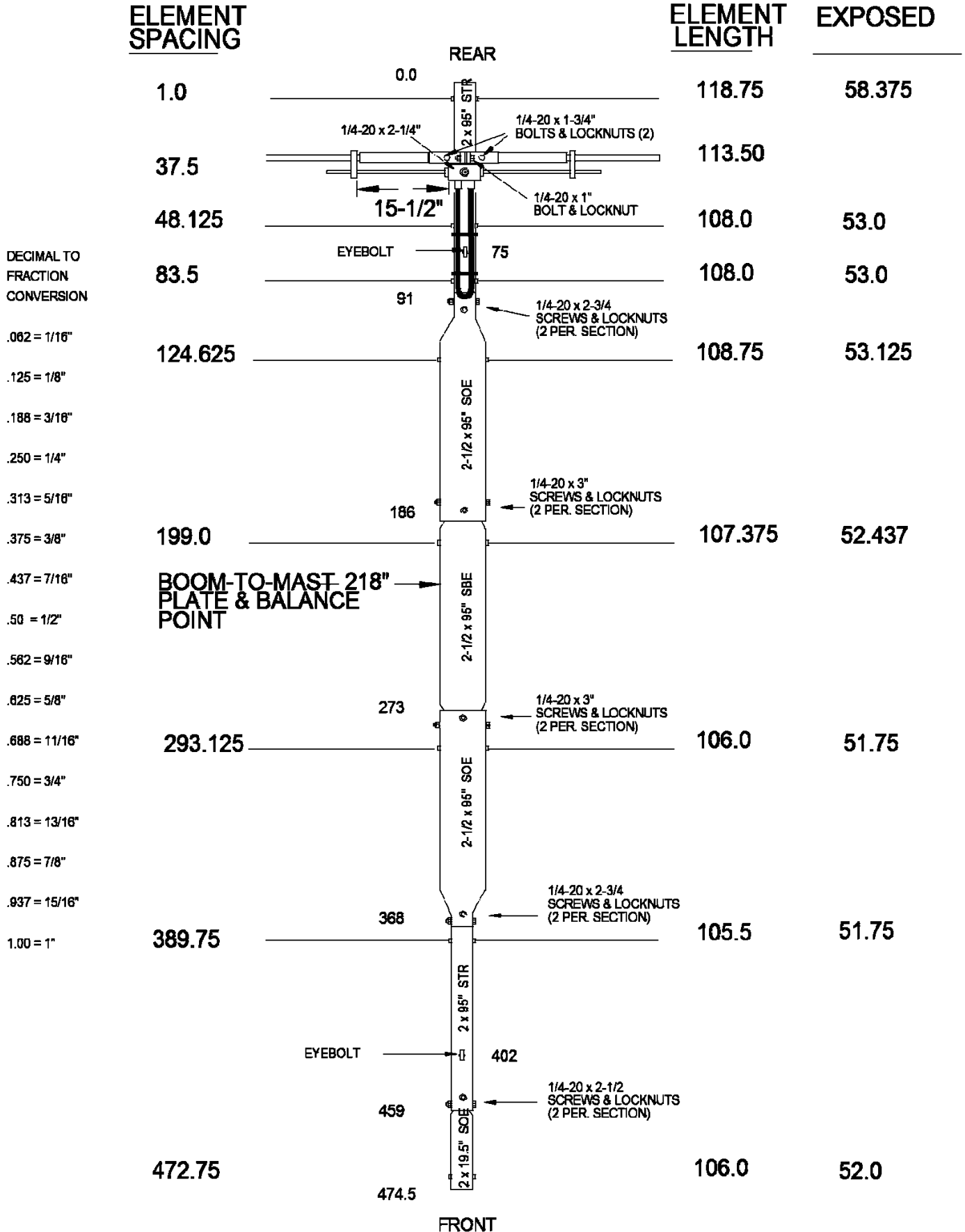

# 6M2WLC ASSEMBLY MANUAL

8. Install the stainless SHAFT RETAINERS. Place the PUSH TUBE in your hand with the end between your thumb and forefinger. Now place a retainer on the end of the push tube (dished into tube) and hold it in place with the same thumb and forefinger. Slide this setup over the 1/4" rod and up to the 3/8" outer sleeve section. Using the PUSH TUBE, slide the retainer down the 3/8 section and up against the button insulator. During this operation DON'T LET THE ELEMENT SLIDE THROUGH THE INSULATORS! (Locking pliers, *lightly* clamped up against opposite button insulator will help maintain center reference and keep you from pushing the first retainer too far, or, grab the opposite side of the element and pull it hard sideways to the boom to preload and increase the friction of the element on the button insulators while pushing the retainer the last inch or two up against the insulator). Repeat on the opposite side. Continue installing the retainers on the rest of the elements.

9. Install the 'T' match block to the bottom of the boom at the 1/4" hole 37-1/2" from the rear. Secure with a 1/4-20 x 2-1/4" bolt. Orient the two balun connectors to face the front of the boom. The single female 'N' connector faces the down (see the hardware assembly sketch). Now slide the ring clamp up against the 'T' match and orient the element channel to the top. Slide the 3/4 x 56-3/4" element sections into the 7/8 x 30" center sleeve, align the holes and drop two 1/4-20 x 1-3/4" bolts through the holes. Set this assembly into the ring clamp channel and add the locknuts and tighten securely at this time. Adjust ring lamp so elements parallel parasitics and tighten clamp bolt.

10. Loosely Install a 8-32 x 1-1/4 screw / locknut and 1/4" set screw into the two SHORTING BARS. Then slide bars over the 3/4" elements and onto the 1/4 inch 'T' match rods. Position inner edge of bars at 15-1/2" from the outer end of the match block. Align the elements and tubes parallel and tighten the bar hardware. NO SWR adjustment should be necessary for a nearly perfect match at the low end of 50 MHz but adjusting these bars should allow you some optimization if you care to place the minimum SWR somewhere OTHER THAN 50.1 MHz.

11. Install the two gold SEAL NUTS on the match block balun connectors with the black neoprene face out. Uncoil the 1/2 wavelength balun cable assembly and form into a large "U" shaped loop. Attach connectors to the match block. Tighten up the 7/16" balun connector nuts gently with a 7/16" end wrench first. Then run the seal nuts up against the face of the connectors and tighten about 1/2 turn more with a 1/2" end wrench.

12. Form the balun cable loop forward along the boom (see Dimension Sheet dwg). If possible, install a feedline section back to the boom-to-mast plate. Secure the balun cable and the feedline as shown on the DIMENSION SHEET using the large black Nylon cable ties. Tighten the ties just enough to secure but not crush or kink cables.

13. Install the two 5/16 x 4 inch EYEBOLTS to the boom in the holes at 75" (Rear) and 72-1/2" (Front) from the ends of the boom. Use 5/16 stainless nuts and lockwashers to secure.

14. Adjust the boom-to-mast plate to vertical. If you've attached the feedline, move the plate to the exact center of balance and tighten U-bolts. Otherwise, secure in its original position. 2" U-bolts are supplied for securing to your mast. To prepare the overhead guy system, begin by *temporarily* installing a 2" U-bolt through the TURNBUCKLE PLATE and into the top set of 2" U-bolt holes on the boom to mast plate (from the boom side). Add a couple of 5/16" nuts to hold in place. Unscrew turnbuckle eyes / hooks until only a thread or two shows inside the turnbuckle body and hook to turnbuckle plate.

15. Uncoil DACRON CORD. Secure one end to rear eyebolt, taking two turns through the eyebolt, then adding three TIGHT half-hitches. Pull hard on cord to set the knots. Repeat for the front eyebolt. Seal cord ends with heat (lighter, propane torch, etc) and tape to main length.

16. Equalize cord length at turnbuckle plate and cut. Put two turns trough rear turnbuckle eye, pull slack out of rope, and add three TIGHT half-hitches. Repeat for front cord section. Seal and tape cord ends.

# 6M2WLC ELEMENT & OVERHEAD DETAIL

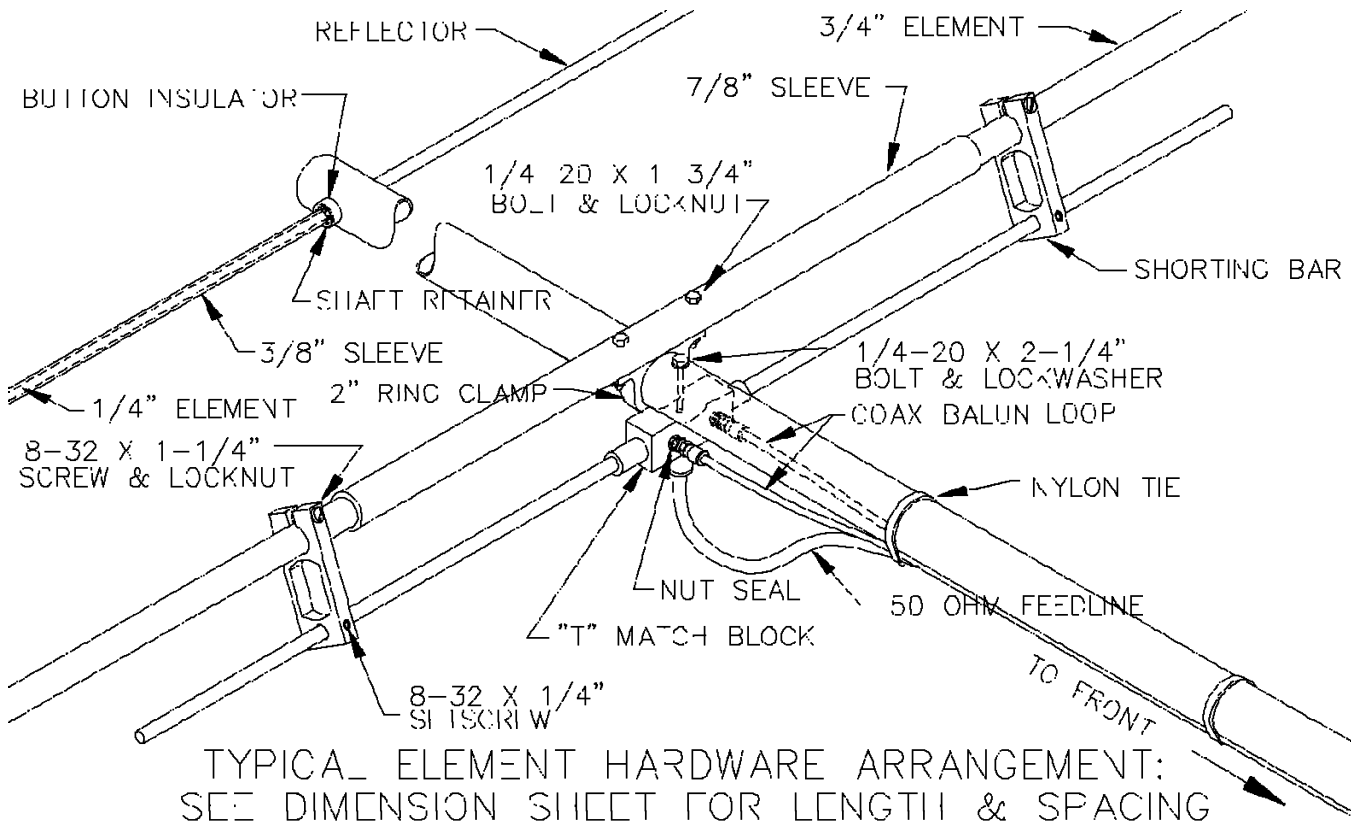

## OVERHEAD GUY SUPPORT

TYPICAL HARDWARE ARRANGEMENT

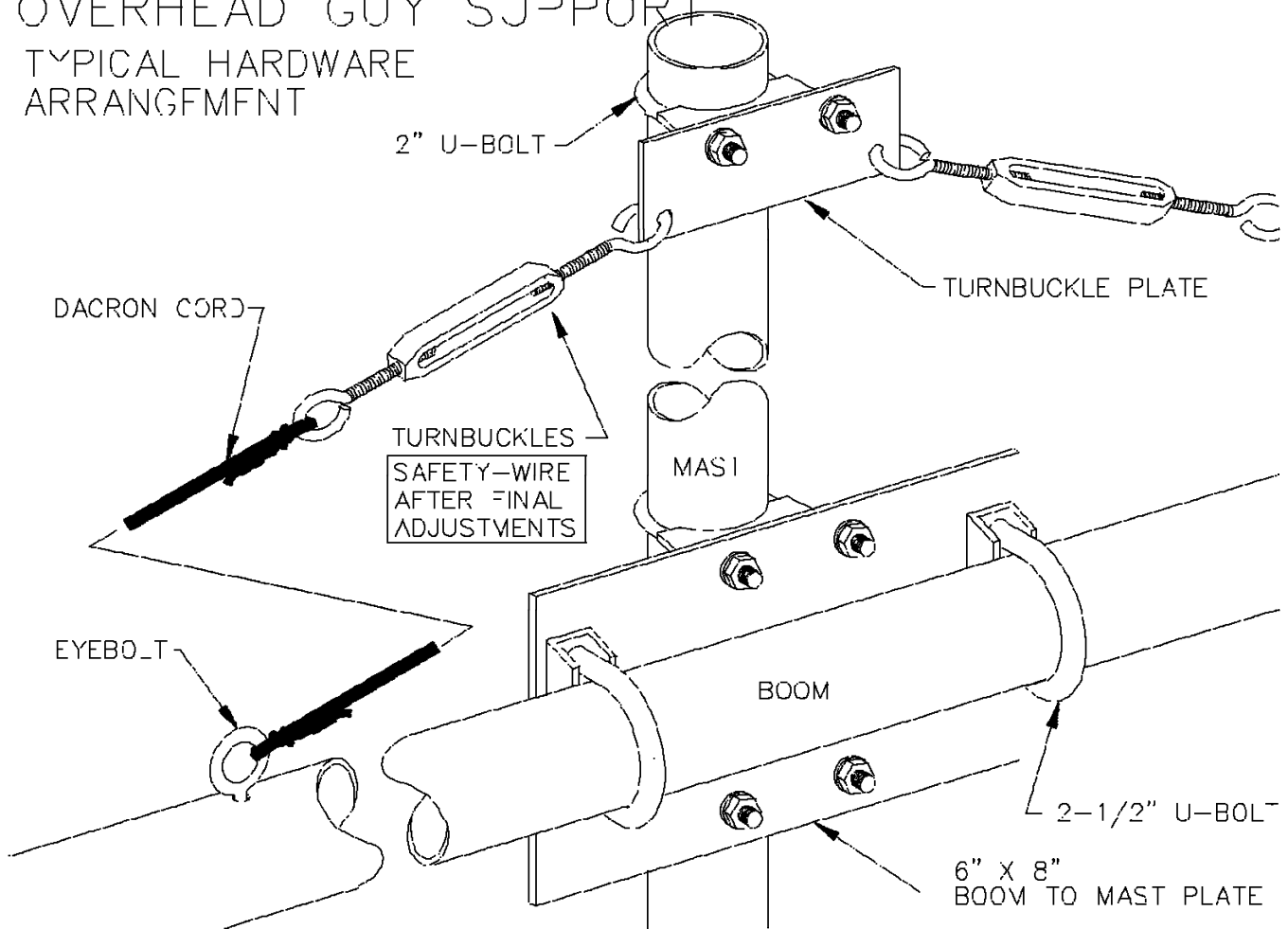

# 6M2WLC ASSEMBLY MANUAL

17. Both cords should now be fairly taut and parallel with boom. Disconnect the 2" U-bolt securing the turnbuckle plate and lift the turnbuckle plate up until the boom bows up slightly. This is approximately how high the plate will need to be mounted on the mast when the antenna is installed.

18. During final installation on the tower / mast, secure the turnbuckle plate at the appropriate height with the 2" U-bolt. Then lean or pull on the cords to increase the tension and tighten the knots. Make sure the knots are not slipping. The Dacron cord does not stretch, but its weave will take a "set" under load. If possible, allow the guy system to take its set overnight. Then, loosen the 2" U-bolt and readjust turnbuckle plate height until boom is straight and level. Finer adjustments can be made with the turnbuckles at any time, if necessary. Safety wire the turnbuckles to maintain settings.

19. This completes the ASSEMBLY. When the antenna is installed in position on the mast, the main feedline can be attached and sealed at that time. REMEMBER to support the feedline at the antenna boom and on the mast. Leave an adequate feedline loop for rotation around the tower. Mount horizontally polarized VHF and UHF antennas at least 40" above or below this antenna to minimize interaction.

20. The 6M2WLC is a large antenna. Use caution when installing. Crank down or lock up your tower before climbing. Watch out for high tension lines! Be sure to use a safety belt. Enjoy your new, BIG, signal on 6!

Carefully designed and manufactured by:

**M<sup>2</sup> ANTENNA SYSTEMS, INC.**

4402 N. Selland Ave.

Fresno, CA 93722

(559) 432-8873 FAX: 432-3059

[www.m2inc.com](http://www.m2inc.com) Email: [sales@m2inc.com](mailto:sales@m2inc.com)

# 6M2WLC PARTS & HARDWARE

DESCRIPTION	QTY
Boom Section, 2 x .065 x 95" alum STR .....	2
Boom Section, 2-1/2 x .065 x 95" alum. SOE .....	2
Boom Section, 2-1/2 x .065 x 95" alum. SBE.....	1
Boom Section, 2 x .065 x 19.5" alum. SOE .....	1
Boom To Mast Plate 6 x 8 x 1/4" alum.....	1
Turnbuckle Plate 2 x 5 x 1/4" alum. ....	1
Dacron rope, 5/16" x 41' .....	1
Turnbuckle, 3/8" alum .....	2
Eyebolt, 5/16 x 4" .....	2
Driven Element 'T' match assembly .....	1
Element, 3/4 x 56.75" alum. ....	2
Element sleeve, 7/8 x 30" alum. ....	1
Ring Clamp, 2" .....	1
Balun, RG-6 x half wave with `F' conns. 50.2 mHz.....	1
Shorting bar 3/8 x 1 x 4-3/8" machined alum. ....	2
Parasitic Element, 3/8 sleeve & 1/4 rod x see "DIMS" .....	8
Nylon ties, heavy duty, black .....	6
U-Bolt, 2-1/2" .....	2
U-Bolt, 2" .....	5
Assembly instructions .....	1

## HARDWARE BAG

Bolt, 1/4-20 x 3" stainless, hex-cap.....	4
Bolt, 1/4-20 x 2-3/4" stainless, hex-cap.....	4
Bolt, 1/4-20 x 2-1/2" stainless, hex-cap.....	2
Bolt, 1/4-20 x 2-1/4" stainless, hex-cap.....	1
bolt, 1/4-20 x 1-3/4" stainless hex cap .....	2
Bolt, 1/4-20 x 1" stainless, hex cap .....	1
Nut, 1/4-20 locking, stainless .....	13
Lockwasher, 1/4 splitting ss.....	1
Nut, 5/16-18, stainless .....	16
Lockwasher, 5/16" stainless .....	16
Nut seal, 3/8-32 with neoprene face .....	2
Shaft Retainer, 3/8 stainless .....	16
Button insulator, 3/8" I.D. black polyethylene.....	16
Screw, 8-32 x 1-1/4" stainless pan head.....	2
Set screw, 8-32 x 1/4" stainless, internal hex .....	4
Nut, 8-32 stainless locking .....	2
Allen wrench, 5/64 .....	1
Push tube tool, 5/8 x 3" alum .....	1